

This equipment has been tested and found to comply with the limits for a Class A digital device, pursuant to part 15 of the FCC Rules. These limits are designated to provide reasonable protection against harmful interference when the equipment is operated in a commercial environment. This equipment generates, uses, and can radiate radio frequency energy and, if not installed and used in accordance with the instruction manual, may cause harmful interference to radio communications. Operation of this equipment in a residential area is likely to cause harmful interference, in which case the users will be required to correct the interference at their own expense.



AP32 AutoPhos Lighting Panel

Instructions contained in this Installation guide should be performed only by qualified persons in accordance with local and national codes. Kele, Inc and its affiliates assume no responsibility for any consequences related to the improper use of this manual.

This document provides instructions on how to install the AutoPhos Series Lighting Relay Panel. The AutoPhos Series comes in four basic units based upon relay capacities: AP08 (8 relay maximum), AP16 (16 relay maximum), AP32 (32 relay maximum), and the AP48 (48 relay maximum). Each unit may contain up to the number of relays indicated. Enclosure sizes for each of the four units will vary. Refer to the AutoPhos Series Data Sheet for more information. Figure 1 shows a AutoPhos Series Lighting Relay Panel. The unit includes a painted steel enclosure with a overhanging plate and door suitable for either flush or surface mounting. Electronics include AutoPhos Series Controller (APCTRL) with on-board RS-485 communication, Relay Interface Module(s), Ribbon cables, Relays, Power supply and Primary power fuse. Refer to Figure 2 and component definition of the APCTRL controller within this manual. The AutoPhos Series is able to receive up to 56 programmable inputs, each requiring home-runs to the AutoPhos panel. To avoid multiple home-runs of standard switches, Kele recommends installing APDAS Series Digital Addressable Switches. Refer to the APDAS Series Digital Addressable Switches data sheet on the Kele website.

Refer to Figure 1 and Figure 2A through Figure 2D for components within the AutoPhos light panels.

AUTOPHOS COMPONENT LOCATION AND DESCRIPTION

High Voltage Section, Left Side, Safety cover removed.

Low Voltage Section

High Voltage Section, Right Side, Safety Cover Installed

APR20 Relays

Relay Interface Board (RIB).

Relay Interface Boards (RIB) Interface Cable.

Switch Input Interface for 25 to 56 Switched Inputs. Not available in 8 and 16 relay versions of the AutoPhos panels.

Grounding Stud. (One in each High Voltage Section)

Power Transformer (120/277 VAC to 24 VAC)

Main Fuse

Main Controller (APCTRL) Board with Switch Input Interface for 1 to 24 Switched Inputs.

Low Voltage Section

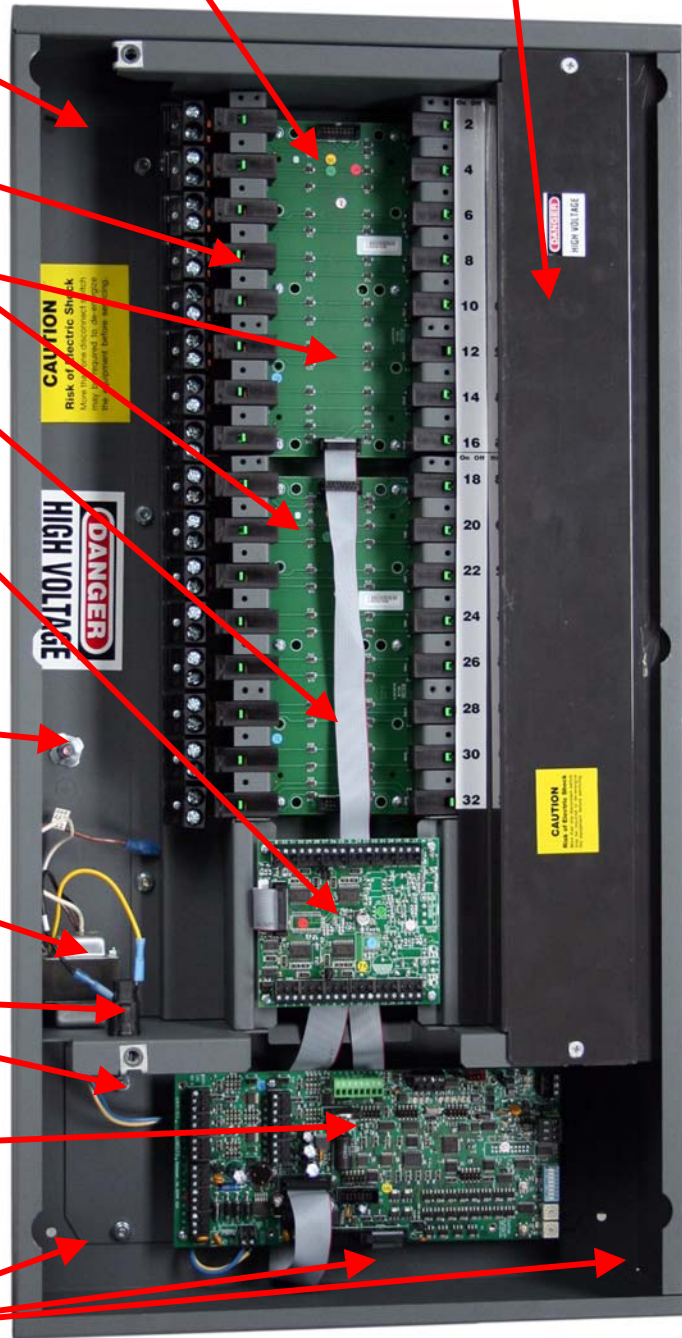

AutoPhos AP32 Shown
Figure 1

Enclosure dimensions	
8-relay	17.2"H x 16.6"W x 5.1"D* (43.7 x 42.2 x 13.0 cm)
16-relay	22.3"H x 16.6"W x 5.1"D* (56.7 x 42.2 x 13.0 cm)
32-relay	31.1"H x 16.6"W x 5.1"D* (79.0 x 42.2 x 13.0 cm)
48-relay	39.9"H x 16.6"W x 5.1"D* (101.3 x 42.2 x 13.0 cm)

AUTOPHOS COMPONENT LOCATION AND DESCRIPTION

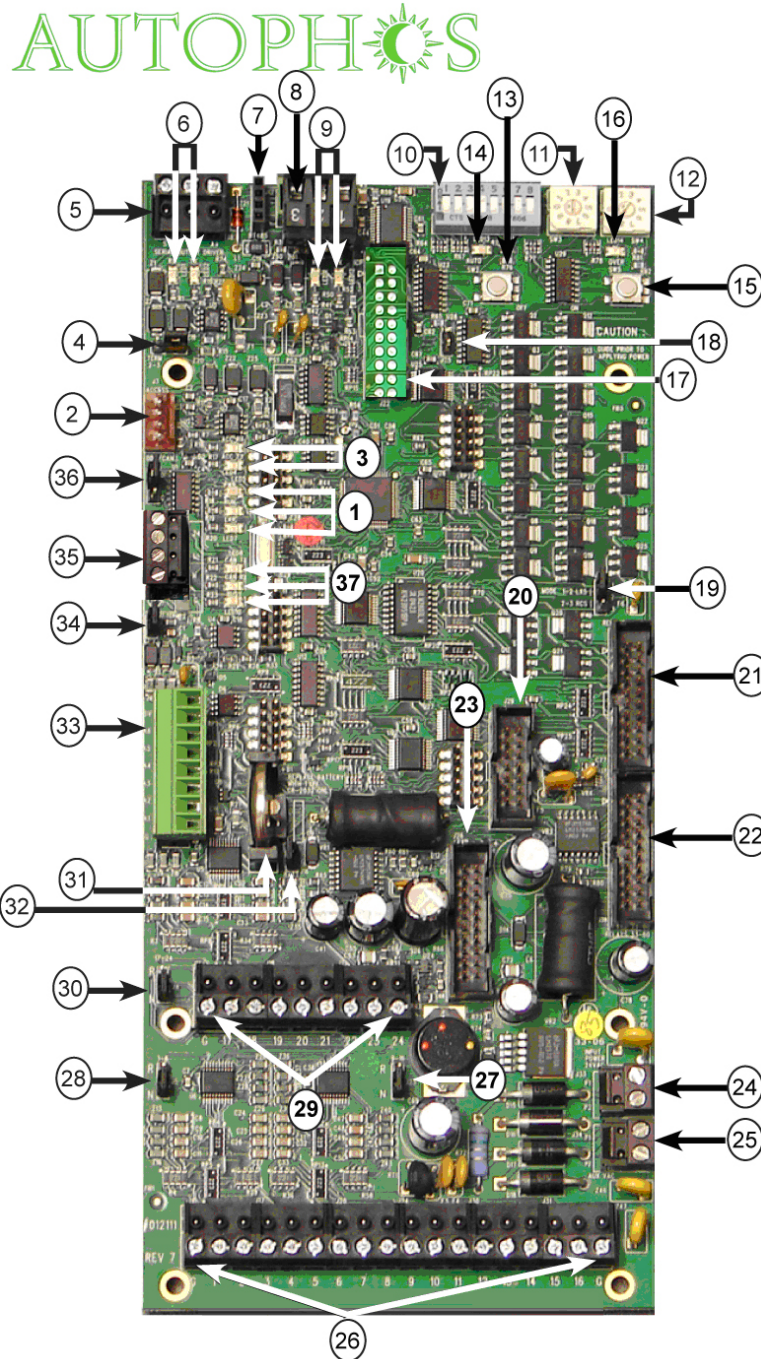

1. Power LED, Run LED, Error LED
Power LED should be on solid as long as AutoPhos controller is connected to 24VAC. Run LED should always be blinking for normal processor activity. Error LED will briefly blink during power up or memory upload then should go to off and remain off show processor memory in normal state.
2. Access Port is used for firmware flash upgrades in the field. Use cable APT for this purpose.
3. Access Rx and Tx LEDs show, receive and transmit activity on the 5-pin Access port.
4. Not used on this control platform
5. Not used on this control platform
6. Not used on this control platform

7. BTS485 socket receives BTS-485 terminating resistor when (rarely) needed on a 485 network.
8. EIA-485 Network Port is the main port used for RS485 communications with the building automation system. On board isolation circuitry provides 500-volt isolation for the RS485 communication network. The terminal blocks can be removed from the AutoPhos controller for easy installation or for quick replacement of an AutoPhos controller.
9. EIA-485 Network Port Rx and Tx LEDs show receive and transmit activity on the RS485 network.
10. Multifunction Dip Switch (Hundreds, SW1) is used to set address and baud rate for AutoPhos controller on the RS485 network. #1-6 are for baud rate settings. For address >99, #7 Up = 200, #8 Up= 100. (#8 ignored when #7 is up, maximum address is 255)
11. Rotary Switch (Tens, SW3) is used to set address 1-99 for AutoPhos controller on RS485 network.
12. Rotary switch (Units, SW4) is used to set address 1-99 for AutoPhos controller on RS485 network.
13. Auto Button (SW2) is used to return AutoPhos controller outputs to pre-override state (Auto Mode) after Over Button is used. Pressing Auto will return AutoPhos controller to pre-override state and will allow execution of serial commands that were stored during override mode.
14. Auto Button LED shows solid ON when AutoPhos controller is not in override state or override-expired state. LED blinking warns that there is no .LPX file loaded into firmware.
15. Over Button (SW5) is manual override of AutoPhos controller outputs. Press to override all outputs ON and press again to override all outputs OFF. AutoPhos controller will not execute serial commands while in override mode. Serial commands received during override mode are stored until AutoPhos controller is returned to Auto mode by pressing Auto button. With no button activity, AutoPhos controller will go to "override-expired" state after approximately 15 minutes and be able to execute subsequent incoming serial commands. To return AutoPhos controller outputs to full Auto mode, press Auto button at any time.
16. Over Button LED shows solid ON when all outputs are in manual override, blinking when all outputs are in manual override OFF. LED is off when AutoPhos controller is in Auto mode.
17. Legacy Port is not a field-accessible feature.
18. Format Pins can be shorted together to erase memory only if address set to zero. **Do not use unless instructed to do so by technical support.** Lost items will be BACnet control programs and .lpx file (from the configuration software). These can be restored through use of Lighting Panel Configuration Software (APSoft) with AppLoader programming tools.
19. AutoPhos controller/RCS Jumper is used to enable AutoPhos controller to control various legacy products.
20. RCS 14 Pin Port receives a 14-pin ribbon cable to control legacy products and retrofit kits. **DO NOT hot swap** this cable.
21. 20 Pin Socket for Outputs 1-32 receives single ribbon cable including both relay 1-16 and relay 17-32 output cards. 20-pin cable may have 16-pin connector on other end depending on type of relay interface card. **DO NOT hot swap.** Ribbon cable may be disconnected to "disable" outputs while programming or testing AutoPhos controller processor.
22. 20 Pin Socket for Outputs 33-60 receives single ribbon cable including both relay 33-48 and relay 49-60 output cards. 20-pin cable may have 16-pin connector on other end depending on type of relay interface card. (These 3rd and 4th RIB cards are identical to 1st and 2nd RIB cards). **DO NOT hot swap.** Ribbon cable may be disconnected "disable" outputs while programming or testing AutoPhos controller processor.
23. LEXP Socket provides connection of up to three optional input expansion modules using 20-pin ribbon cable. **DO NOT hot swap** this cable.
24. Input Power 24VAC transient protected, surge suppression to 1.8 joules. The terminal block can be removed from the AutoPhos controller for easy installation or for quick replacement of an AutoPhos controller.

25. Aux Power Tap for 24VAC accessories, runs off of input power, is interchangeable with input power pins.
26. Switch Inputs 1-16 for hard wire “home run” style override switches and occupancy sensors. The terminal blocks can be removed from the AutoPhos controller for easy installation or quick replacement of the entire controller. AutoPhos controller has 24 onboard input connections.
27. Jumper for Switch Inputs 9-16 for provides capability to select the AutoPhos Controller to power its inputs or allow an external power source to power its inputs. Occupancy sensors that use 24VDC to power the sensor are typical applications that are externally powering an input. Jumper in the “N” position configures the inputs to be dry contact and powered by the AutoPhos controller. Jumper in the opposite position configures the inputs to be externally powered by up to 24VDC. Each jumper affects only its respective eight inputs only. There is one jumper for each of the AutoPhos controller Controller’s eight inputs.
28. Jumper for Switch Inputs 1-8 (See above)
29. Switch Inputs 17-24 (See above)
30. Jumper for Switch Inputs 17-24 (see above)
31. Battery Holder for battery replacement type CR-2032, 3 volt. Battery does not function as long as AutoPhos controller is powered. Battery is for backup of the real time clock and BACnet control programs during a power outage. All other programming is held in non-volatile memory.
32. Battery Jumper disengages battery same as if removing the battery. See previous entry.
33. Analog Inputs 1-6 provides 6 inputs for accepting 0-5 VDC signals from photo sensors such as Lumisys LS5 series. Power (5V) and return (G) are also provided to power the sensors from the AutoPhos controller.
34. Not used on this control platform
35. AutoPhos Digital Addressable Switch Network Port receives the 4-wire (Belden #1502P or equivalent) network for addressable override switches. The terminal blocks can be removed from the AutoPhos controller for easy installation or for quick replacement of an AutoPhos controller.
36. Jumper for AutoPhos Digital Addressable Switch Network switches the port from between two modes. Typically never touched.
37. AutoPhos Digital Addressable Switch Network Rx,Tx and Busy LEDs show the network outbound/inbound communication and processor activity.

AUTOPHOS COMPONENT LOCATION AND DESCRIPTION

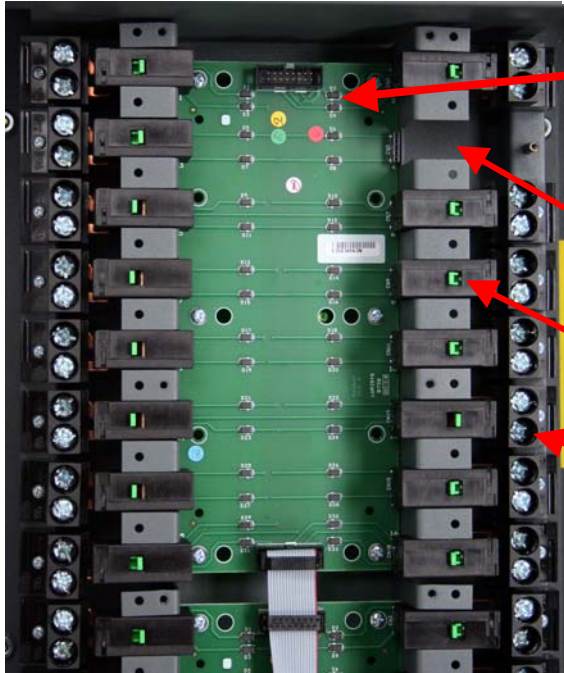

Relay Interface Board (RIB)

Open Relay Slot. Shown as an example of a panel not completely filled with maximum relay count.

Low Voltage Side of Relay with Override Switch.

High Voltage Terminal Block Side of Relay.

**AutoPhos APR20 Relays
Figure 2B**

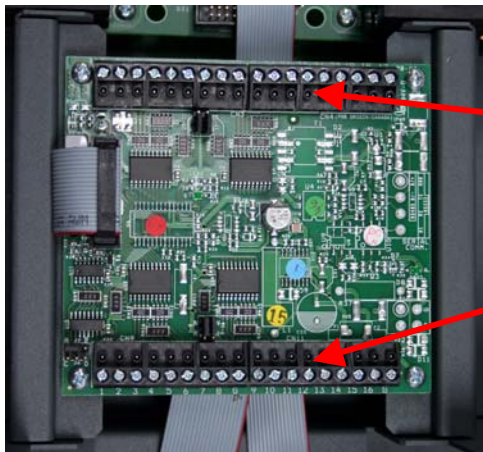

16 Switch Inputs (Inputs 41 through 56)

16 Switch Inputs (Inputs 25 through 40)

**Switch Inputs 25 through 56 (AP32 and AP48 only)
Figure 2C**

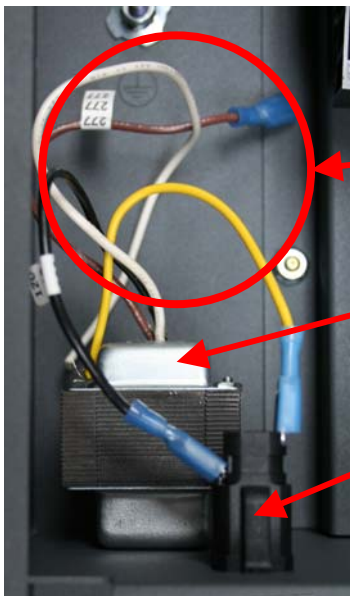

Wiring for 120 VAC or 277 VAC Panel Power

Power Transformer (120/277 VAC to 24 VAC)

Fuse

**Power Transformer
Figure 2D**

Installation

Mounting the AutoPhos Enclosure

- 1. Knockout Holes for high and low voltage conduit connections.** Figure 3 illustrates areas in the AutoPhos Series enclosure where conduit holes for high and low voltage wiring can be made. Remove the interior and the AutoPhos Controller (APDAS) board. If the panel was shipped with electronics installed, remove the interior with electronics until all holes for conduit are punched and all metal shavings are removed. Metal shavings from drilling could lodge in the electronic components and cause damage.
The main interior is held to the enclosure by flange nuts. The APDAS is secured with 6 screws. Remove the cables from the APDAS board making note of there connection and orientation for reassembly. Remove the interior and place it away from any work area before drilling holes for conduit.
- 2. Mount the enclosure with anchors and screws** according to Figure 3.
Figure illustrates the location of the panel mounting holes. The top two mounting holes of the panel enclosure are keyhole shaped so you can slide the unit over mounting screws, avoiding the need to hold the unit while trying to secure the mounting screws. Use wall anchors capable of supporting more than 80 pounds (48 relay unit).
If flush mounting, secure the enclosure between the wall studs. Be sure to allow for the thickness of the drywall and 7/8" for the overhang of the cover so that the panel's cover will mount flush on the finished wall and away from adjacent panels.

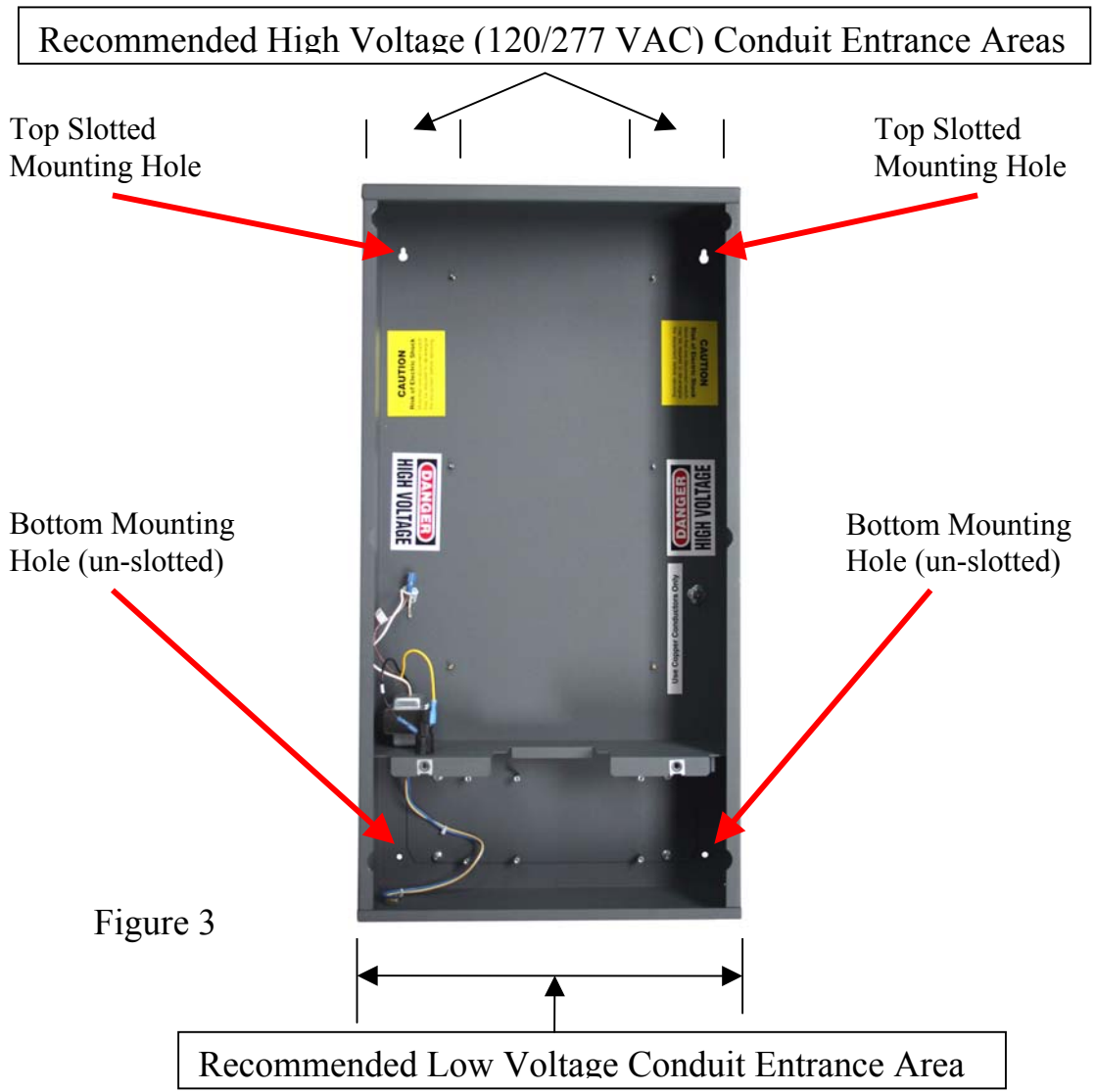

Connecting the Power Supply

The AutoPhos panel can be powered by either 120 or 277VAC. A fuse and dual primary transformer are utilized to offer maximum flexibility during installation. This factory mounted transformer powers the AUTOPHOS Series controller and associated low voltage coils on the contactors (relays).

1. **If connected, remove the power harness from the AutoPhos controller.** See Figure 4 for location of the harness on the controller. Remove the harness by lifting on the terminal block of the harness.
2. **Connect main power to the transformer and fuse assembly.** Locate the Common (white) wire and the hot (black) wire for connection to main power. Each of these wires contains a “quick connect” connector. To connect a power wire to this connector, pinch the end of the connector to open it for wire insertion. Release the end of the connector with the wire inserted to allow the connector to hold. Figure 4 shows the connectors on the white and black wires.
3. **Locate wire with correct voltage and connect to fuse.** Refer to Figure 5. Power is connected by choosing the proper voltage wire stemming from the transformer and connecting that wire to the fuse holder. Each wire is labeled either 120V or 277V. The 120V wire should be black, and the 277V wire should be brown. If this is not the case contact the factory immediately. Each wire is terminated with a spade connector that inserts over a contact on the fuse holder.

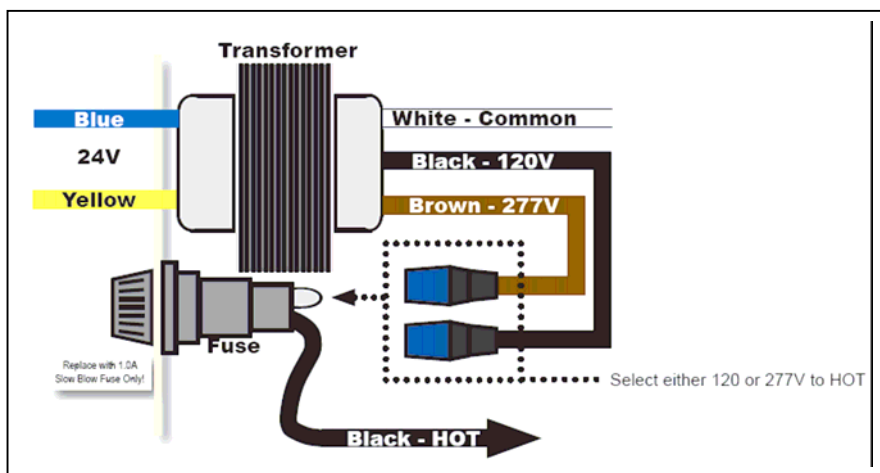
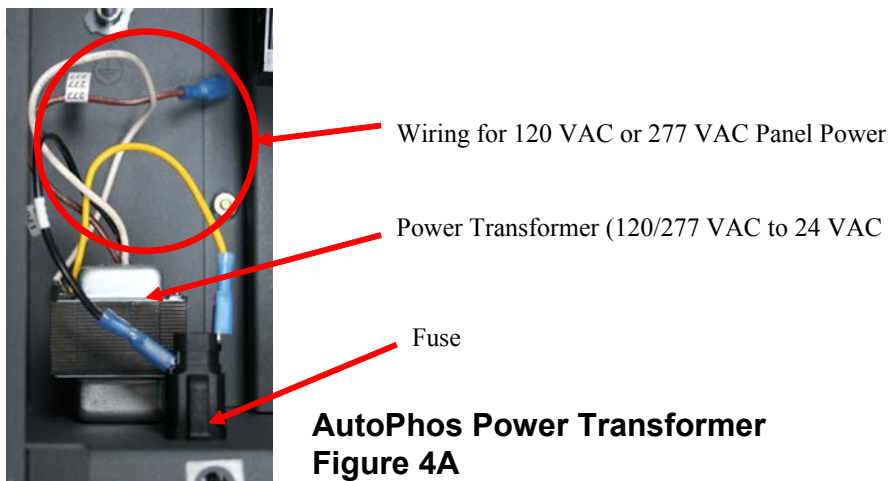

Connecting Branch Circuit Wires

The AUTOPHOS Series panel is equipped with contactors capable of switching up to 20 amperes at 277 VAC (Canadian versions, 347VAC). Each contactor can be easily assigned to any of the unit's zones. Be sure not to exceed 20 amperes per contactor. If the high voltage wiring requires both 120V and 277V, a Lumisys **LDIV35** High Voltage Divider will be required.

WARNING! Disconnect high voltage power to all circuits before connecting them to the AutoPhos panel. Failure to do so could result in serious injury.

1. Pull branch circuit wires through high voltage conduit. Note: All wiring should be in accordance with local regulations and the National Electric Code. Control signal wiring to the low voltage side of the unit should not be run in the same conduit as line voltage wiring or other conductors that supply highly inductive loads such as generators, motors, or high voltage circuits located on the high voltage side of the unit.

If 120V and 277V branch wires must be connected to relays on the same side of the panel do not run these wire through the same conduit. See Figure 1 for high (load) and low (24V) voltage areas of the panel.

2. Install each branch circuit in one contactor as shown in Figure 6B. Each branch circuit can be installed in a contactor as shown in Figure 6 below

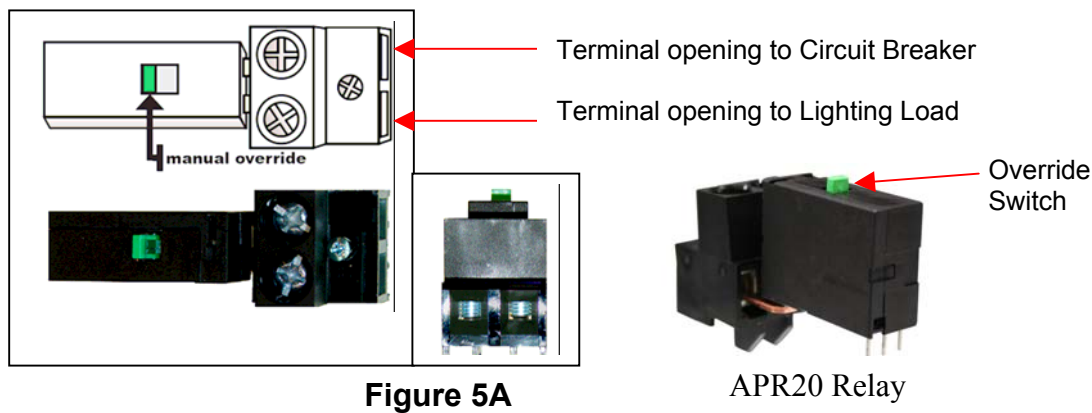
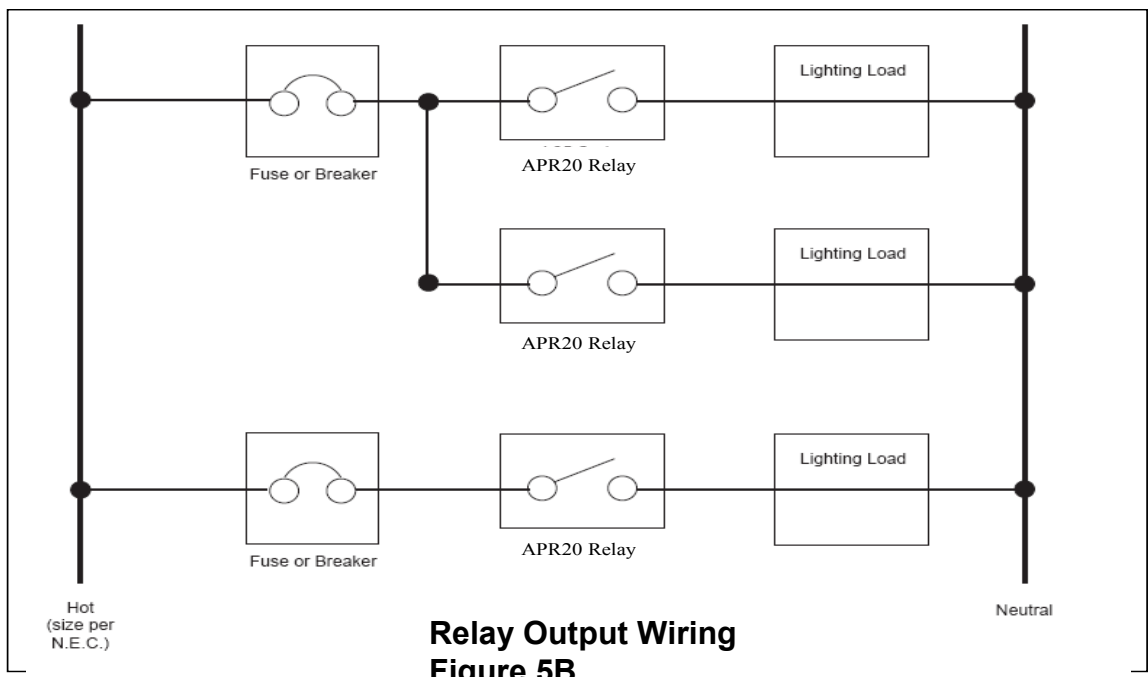

Figure 5A

APR20 Relay



Relay Output Wiring
Figure 5B

Switch Inputs and Jumpers on AutoPhos controller and LEXP

Switch input connections are made on the AutoPhos controller main processor card, The AutoPhos controller. The AutoPhos controller comes standard with 24 programmable inputs. The AP32 and AP48 have an expansion board (LEXP) installed that increases input capacity to 56. Note LEXP cards are jumper addressed A, B, C and D at the factory. Always power down the AutoPhos controller before connecting or removing card. Never Hot Swap

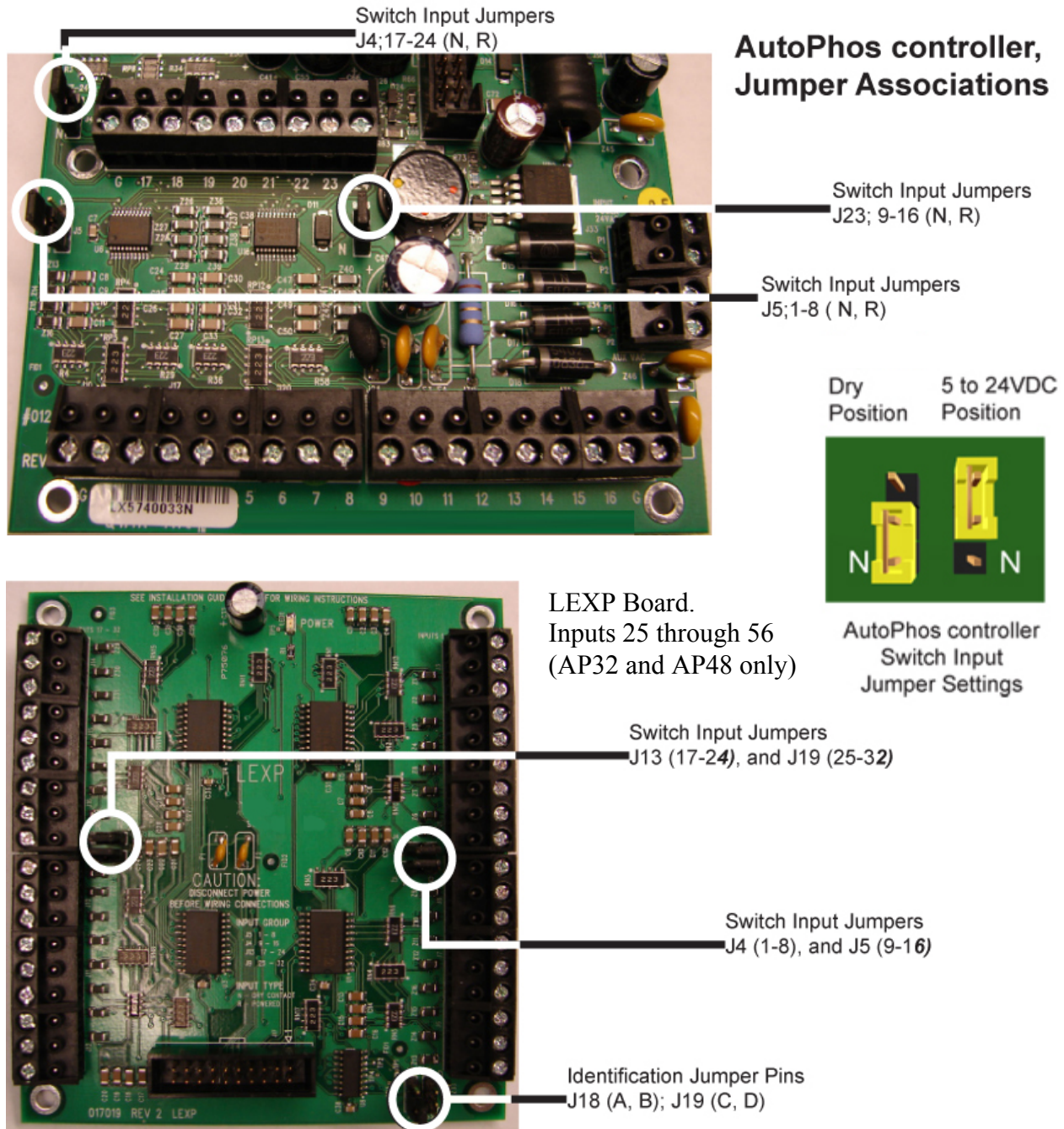

Figure 6A and 6B

The inputs can be set in software as Momentary on, Momentary off, Momentary on/off, Maintained, Linked, or State change. Each section has an accompanying jumper that sets whether its associated eight inputs will be up to 24 VDC or dry (0 VDC).

Each jumper set has 3 pins, one of which is labeled “N”. The “N” jumper is for setting the switch inputs for dry contact. The “up to 24” pin of the jumper pin is not labeled. Figure 4 shows how to place jumpers properly.

The jumper must be set before wiring.

Note If one switch input is dry, the entire section of eight switch inputs must also be dry contacts, and the associated jumper must be in the “dry” position. If one switch input is externally powered 5 to 24 VDC, the entire section of eight switch inputs must also be 24 VDC, and the associated jumper must be in the “24” position.

CAUTION! Before handling any components on the circuit board, the installer should be grounded to prevent damaging the board.

1. Disconnect power to the controller.
2. Remove the power harness on the controller by lifting on its terminal block.
3. Set jumpers.
4. Connect the switches to the controller.
5. Connect one end of the switch or contact to terminal “G” and the other to any terminal 1-24. Momentary switches which have both an On and Off contact will require two switch inputs on the controller. See Figure 6C for sample wiring diagrams for each input type. Switch input terminal blocks are screw type. Land wires by unscrewing, inserting the stripped wire, and tightening the screw.
6. Reconnect power to the controller.

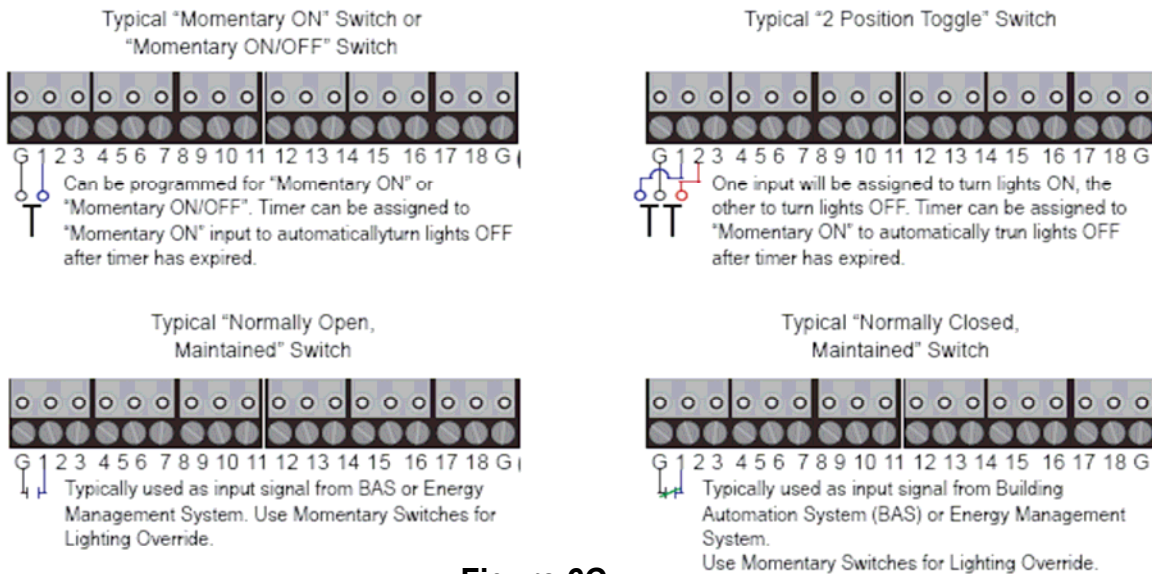

Figure 6C

Process for changing Jumper Settings Safely

1. Remove power to the controller. Remove the yellow/blue power harness by lifting on its terminator block.
2. Set jumpers.
3. Connect the switches to the controller. Connect one end of the switch or contact to terminal “G” and the other to terminal “1-24”. Momentary switches which have both an ON and OFF contact will require two switch inputs on the controller. Switch input terminal blocks are screw type. Land wires by unscrewing, inserting the stripped wire, and tightening the screw.
4. Reconnect power to the controller.

Analog Inputs

The AutoPhos controller comes with six inputs for the Analog type, 3-wire, 0-5 volt photocells. The photocell is powered by 5V from the AutoPhos controller. The power circuit includes the Red (5V hot) and the Black (ground) wires. The yellow wire carries the 0-5V input signal from the photocell which is then scaled to a value used by the Panel Configuration Software (Part #: APSofT).

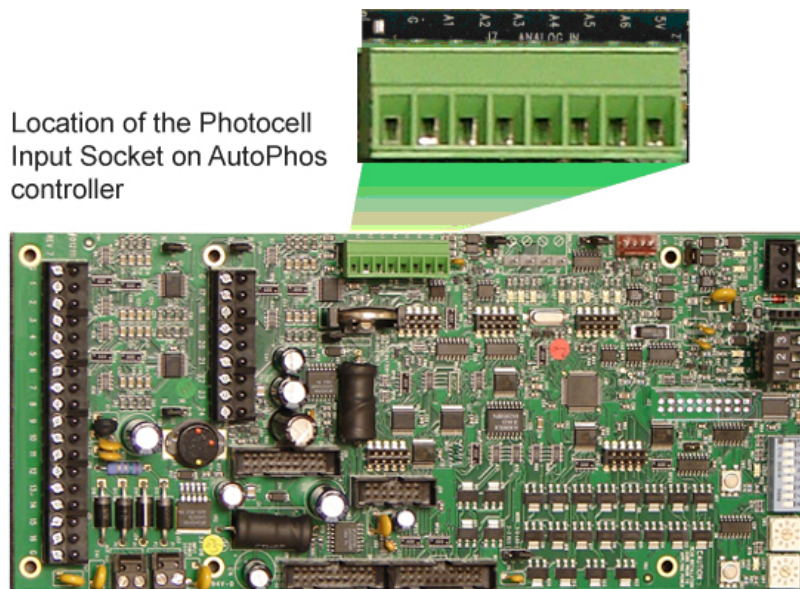

Figure 7A

Example of single photocell installed on AutoPhos controller

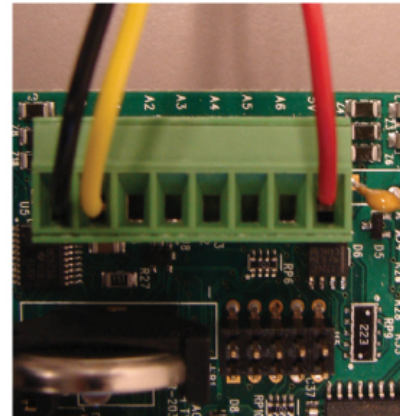
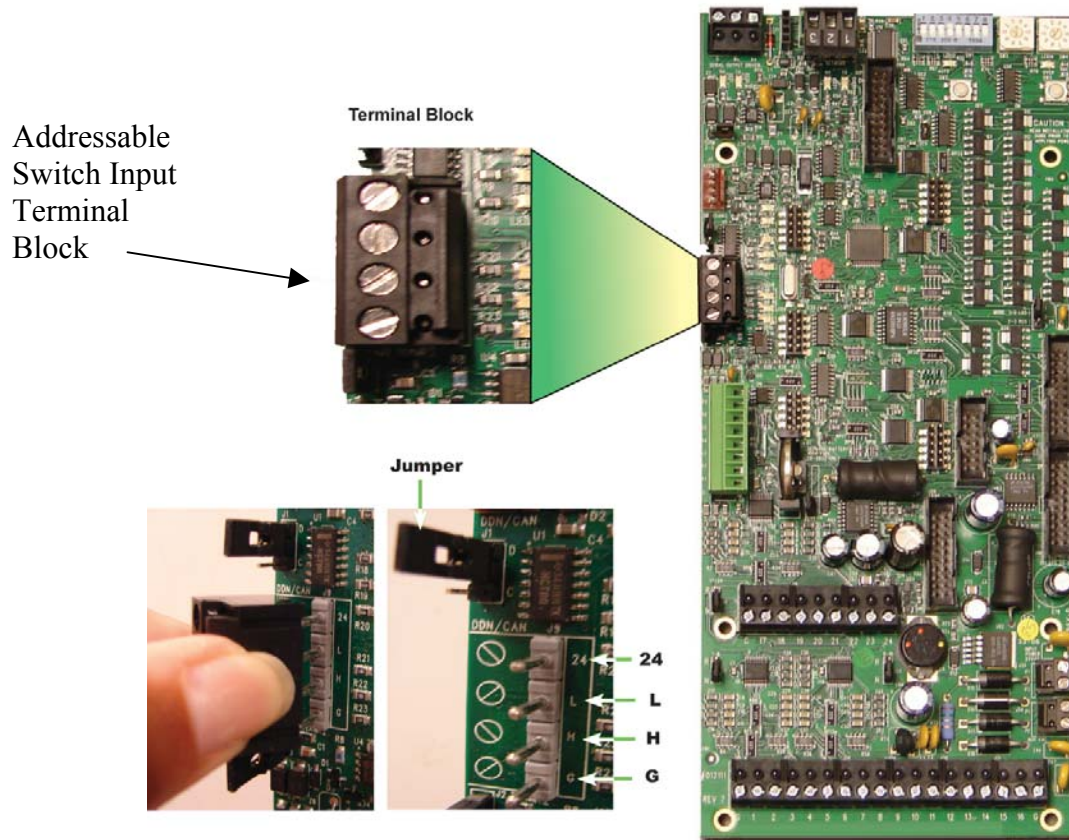

Figure 7B

1. After installing the Photocell, splice extension wires to photocell wires. If possible use the same color wires provided with the photocell. A maximum of 500 feet of wire total is allowed, measured from the photocell to the AutoPhos controller socket. Use 18-22AWG wire.
2. Remove power from AutoPhos controller.
3. Join red wires from all sensors into pigtails and terminate in single termination point marked "5V" on AutoPhos controller main board.
4. Connect each yellow signal wire from each sensor into individually marked A1-A6 on AutoPhos controller main board.
5. Join black wires from all sensors into pigtails and terminate in single termination point marked "G" on AutoPhos controller main board.
6. Reconnect power to the AutoPhos controller.

AutoPhos Addressable Switch Network Port and Jumpers

Make all connections before applying power to the AutoPhos controller main board. Connect the network of switches to the AutoPhos controller port marked DDN/CAN and set the jumper to DDN (upper 2 pins) as shown in picture below. Remove terminal block to view PCB markings designating pins “ 24, I, H, and G”. The AutoPhos controller can be used to loop power up to 8 two button AutoPhos Addressable Switch Network switches or up to 16 one-button AutoPhos Addressable Switch Network switches. For higher quantities of switches, use 24VCD auxiliary power supply.



Addressable Switch Interface to AutoPhos
Figure 8

Connecting the RS-485 Network. Configuration Details **EIA-485 Port and BTS485 Socket**

The AutoPhos is capable of being networked to a Building Automation System over a two or three wire RS-485 communication network. A terminal block is provided to connect the two communication wires plus the shield wire. Use 18 AWG stranded 600V insulated wire. The RS-485 connection location and labeling is illustrated in Figure 16.

1. Disconnect power to the AUTOPHOS CONTROLLER.
2. Connect incoming and outgoing transmit "+" to "A+" on the RS-485 connector. As with switch inputs, a screw type terminal block is provided.
3. Connect incoming and outgoing transmit "-" to "B-" on the RS-485 connector.
4. When a shield wire is used, either splice incoming and outgoing shield wires together or connect to "S" on the RS-485 connector.
5. Reconnect power to the AUTOPHOS CONTROLLER.

The AutoPhos controller is capable of being networked to a Building Automation System over a two or three wire EIA-485 communication network. A terminal block is provided to connect the two communication wires plus the shield wire. (EIA-485 wires are not provided by default.) Use 18 AWG stranded 600V insulated wire, twisted pair with shield. The EIA-485 connection location and labeling is illustrated in Figure 9.

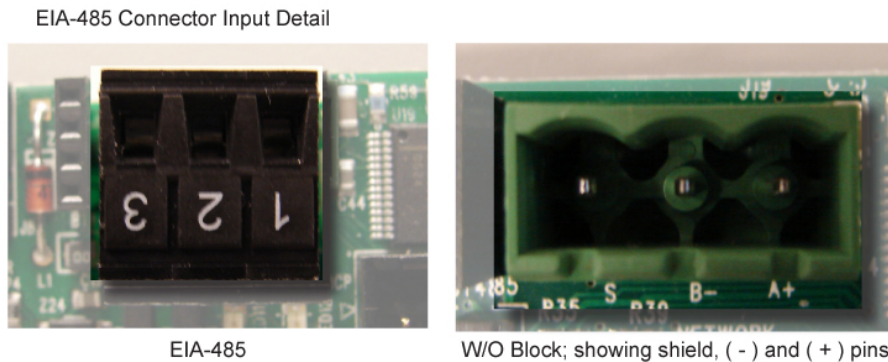

Figure 9

SETTING-UP NETWORKING

Using the Dip and Rotary Switches.

* AutoPhos controller must be power-cycled for changes to take effect

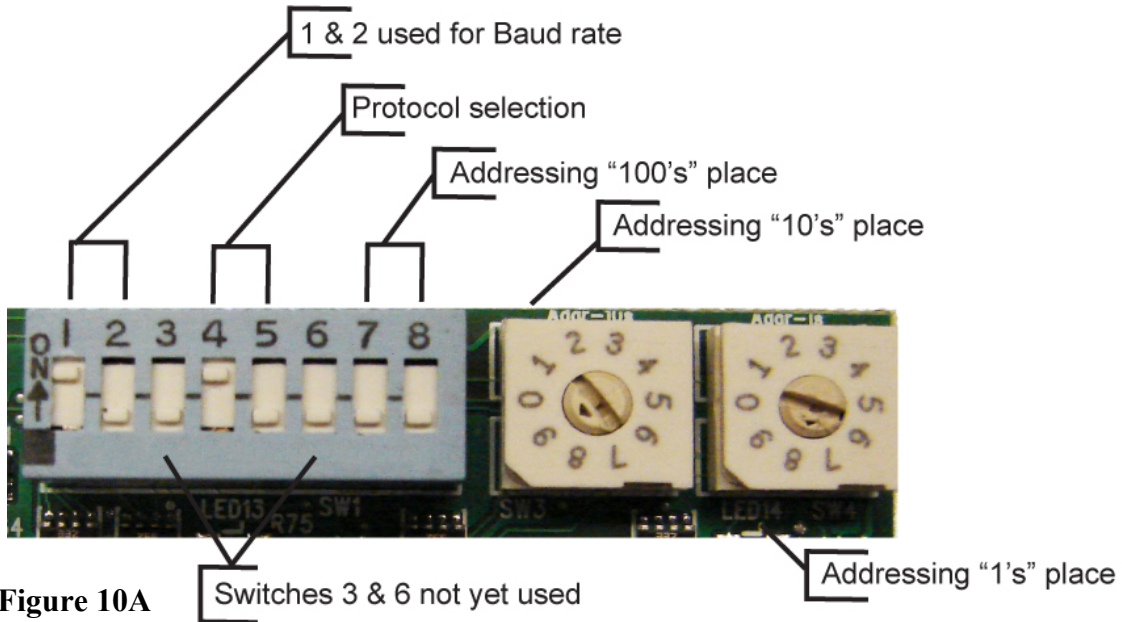

Figure 10A

Addressing - Dip switches #7, #8 and Rotary Switches

For addressing 1-99, just use the rotary switches:

SW3 is the 1's. SW4 is the 10's. Leave dip switch #7 and #8 down, (Off).

For address 100-255, add the dip switch settings:

Dip switch 7 On = 100

Dip switch 8 On = 200 (#7 is ignored when #8 is On)

Protocols - Dip Switches #4 and #5

ASCII Protocol - N2 (at 9600 BAUD)

Figure 10B

BACnet MSTP Protocol (at 9600 BAUD)

BACnet MSTP Protocol (at 19200 BAUD)

BACnet MSTP Protocol (at 38400 BAUD)

BACnet MSTP (at 76800 BAUD)

TYPICAL NETWORK WIRING

BACnet MS/TP, N2, Lumisys Open Protocol 2 Wire EIA-485

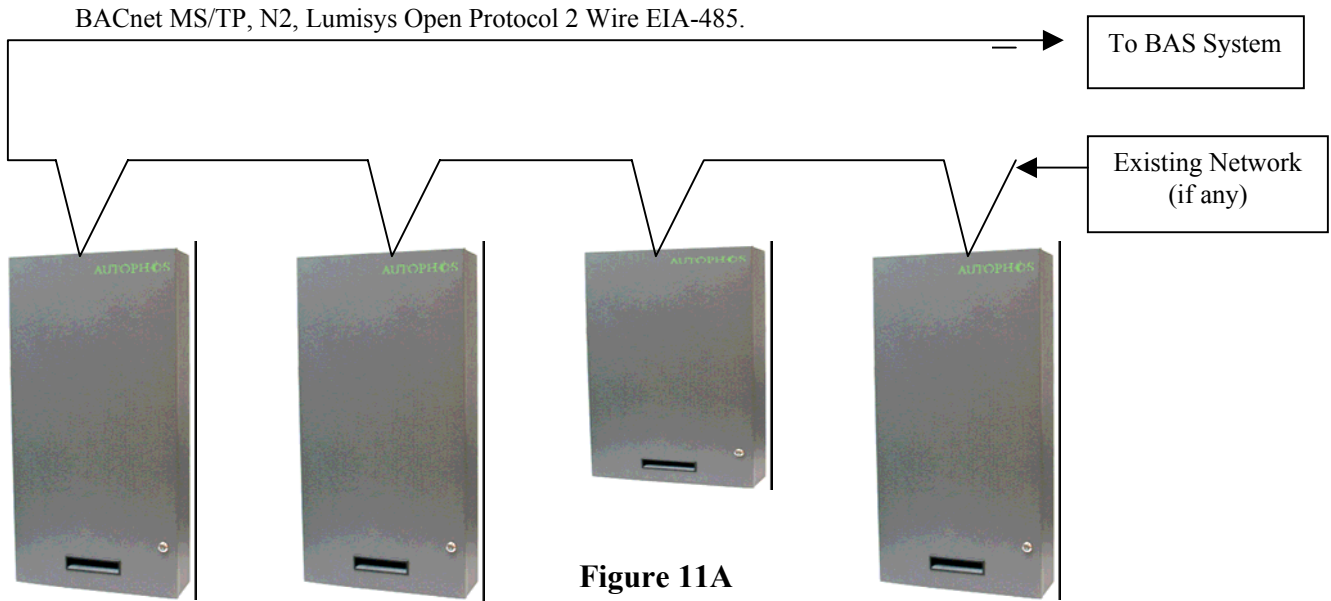

BACnet PTP, Modbus RTU, Modbus ASCII

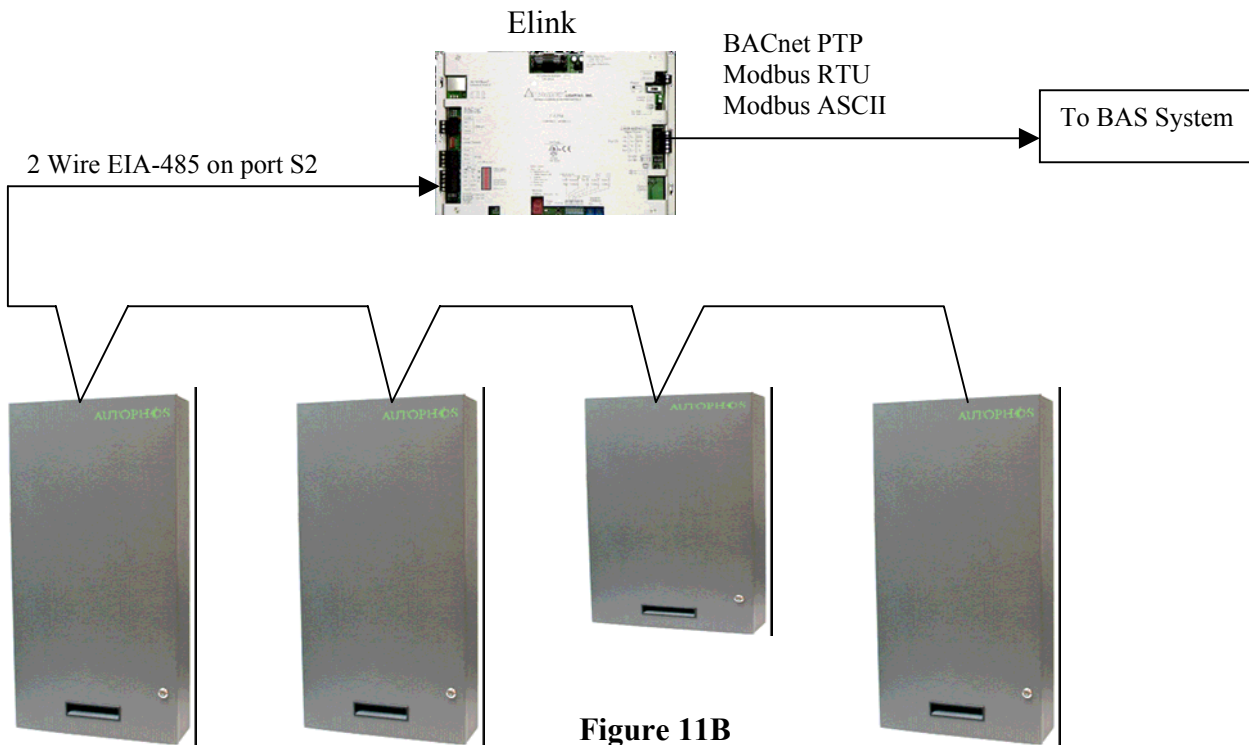

BACnet over 10/100Base T Ethernet, BACnet IP

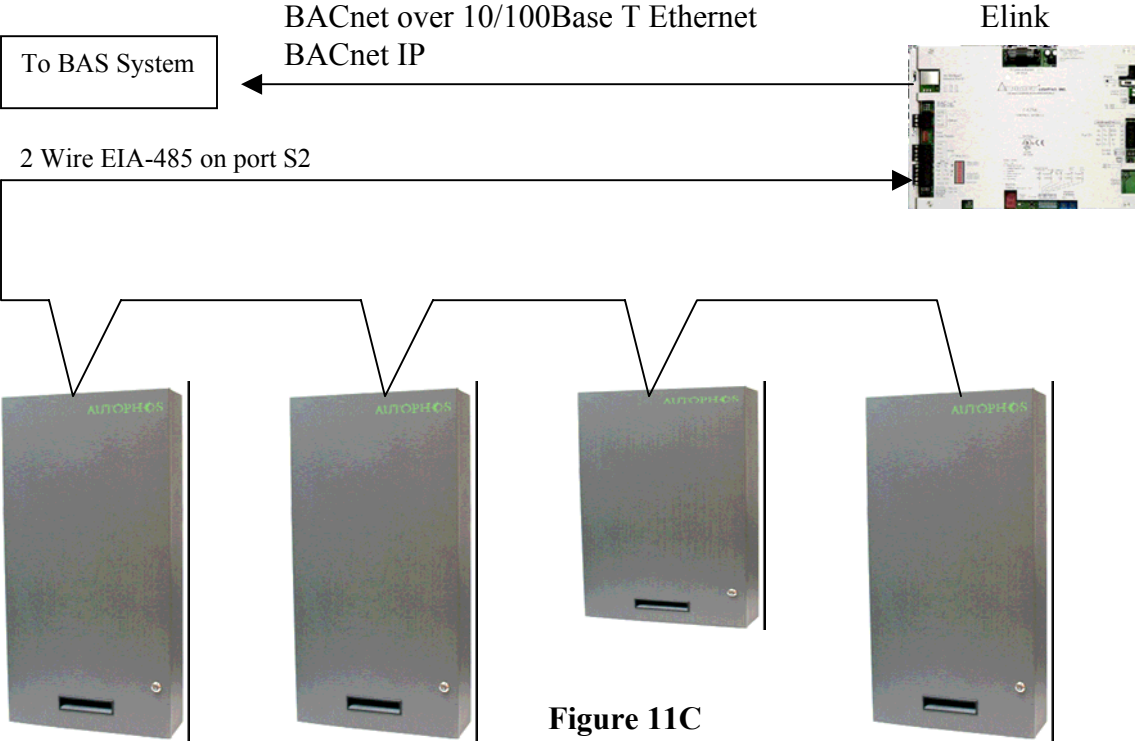

Figure 11C